

Product specifications	DOC. No.: 651-0163-01	Rev.: C	Page: 1/6
	P/N: KH-252515-G2.1	Approved/Date Henry 06/01/18'	Approved/Date Henry 06/01/18'

1、Scope

This product is applied to RF circuits and provides a switch interface for circuit tests . And it' s the second type of the “MINI RF CONNECTOR” , with excellent performance and less space occupation.

2、Technology Parameters

- 2.1 Voltage Rating 250VAC
- 2.2 Current Rating 1A
- 2.3 Frequency Range DC~6GHz
- 2.4 Impedance 50Ω
- 2.5 Operating Temperature -40℃ ~+85℃

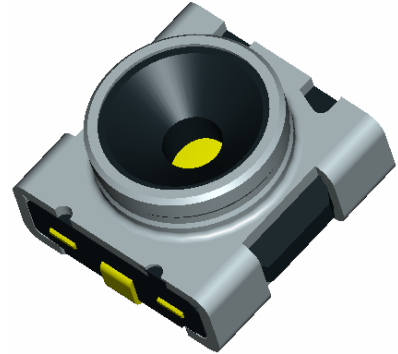

3、Electrical Characteristics

- 3.1 Insulation Resistance 500MΩ
- 3.2 Dielectric Withstanding Voltage 300V AC
- 3.3 Contact Resistance 120 mΩ max
- 3.4 Voltage Standing wave Ratio(VSWR) 1.2 max (DC~3GHz) , 1.3 max (3~6GHz)

3.4.1 Test Method:

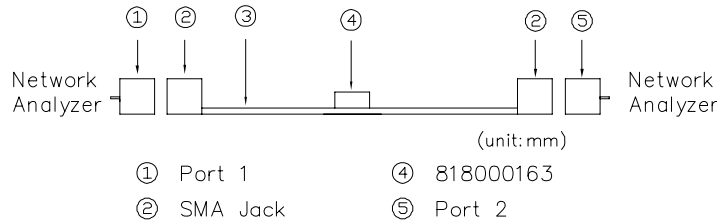

3.5 Isolation

20dBmin (DC~3GHz) , 15dBmin (3~6GHz)

3.5.1 Test Method:

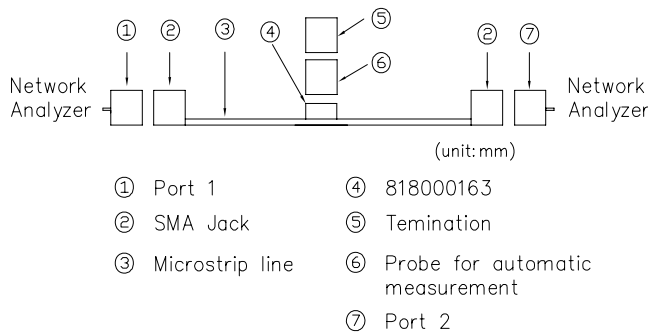

3.6 Insertion Loss

0. 10dBmax (DC~3GHz) , 0. 20dBmax (3~6GHz)

3.6.1 Test Method:

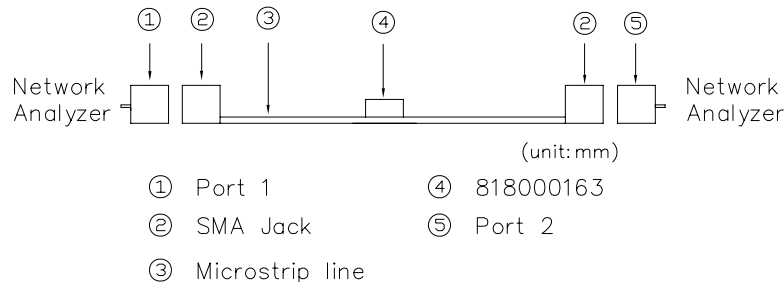

Product specifications	DOC. No.: 651-0163-01		Rev.: C	Page: 2/6
	P/N:	Approved/Date	Approved/Date	Initiated/Date
	KH-252515-G2.1	Henry 06/01/18'	Henry 06/01/18'	SAM 06/01/18'

4、Mechanical Characteristics

- 4.1 Contact Retention Force 3.4N~4.5N
- 4.2 Mating Force 30N or less
- 4.3 Unmating Force 5N~40N
- 4.4 Mechanical Durability 500 Cycles
- 4.5 Adhered Force of Solder 50N

4.5.1 Test method:

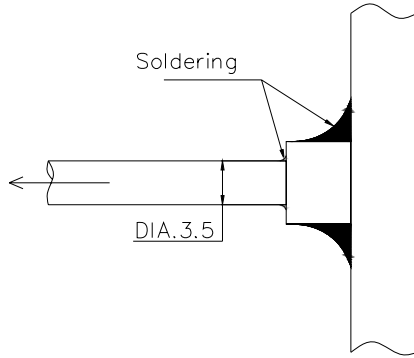

- 4.6 Shock Acceleration: 750m/s² (peak-to-peak). Period: 6m sec. Waveform: Half-sine.
- 4.7 Vibration Frequency Range:10Hz~30Hz Amplitude: 3mm.

5、Environmental Characteristics

5.1 High Temperature Cycling

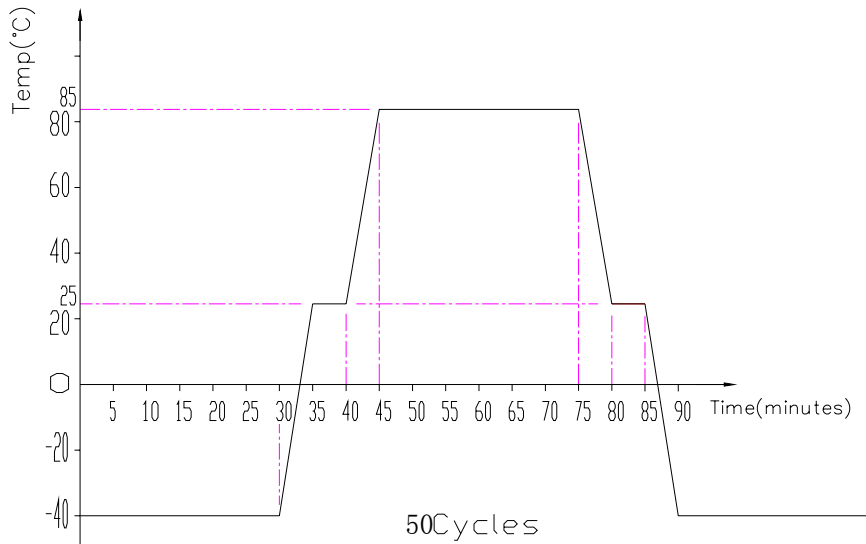

- 5.2 Humidity, Steady State: Temperature: 60°C Humidity: 95% RH Period: 96 hours
- 5.3 Salt Spray Temperature: 35°C Solution Conduction: 5% , Period: 48 hours



P/N:

KH-252515-G2.1

Approved/Date

Henry
06/01/18'

Approved/Date

Henry
06/01/18'

Initiated/Date

SAM
06/01/18'

6、SMT Soldering Condition

6.1 Recommended IR Temperature & Time Curve

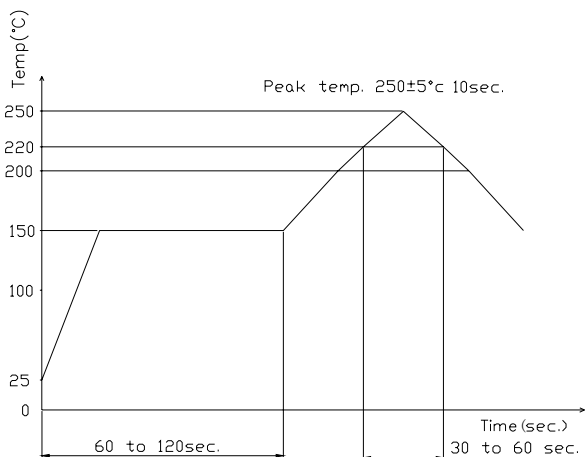

6.2 IR Extreme Temperature & Time Curve

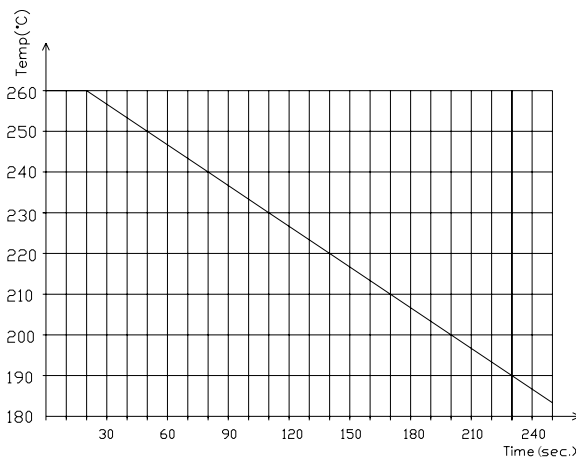

7、Profile Dimensions

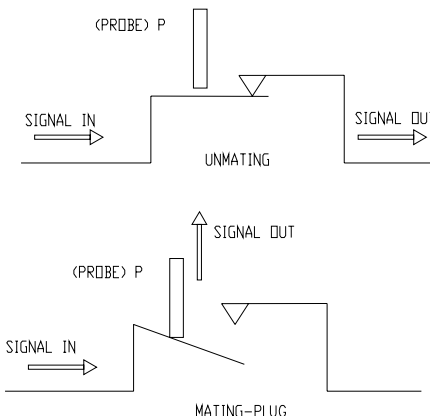
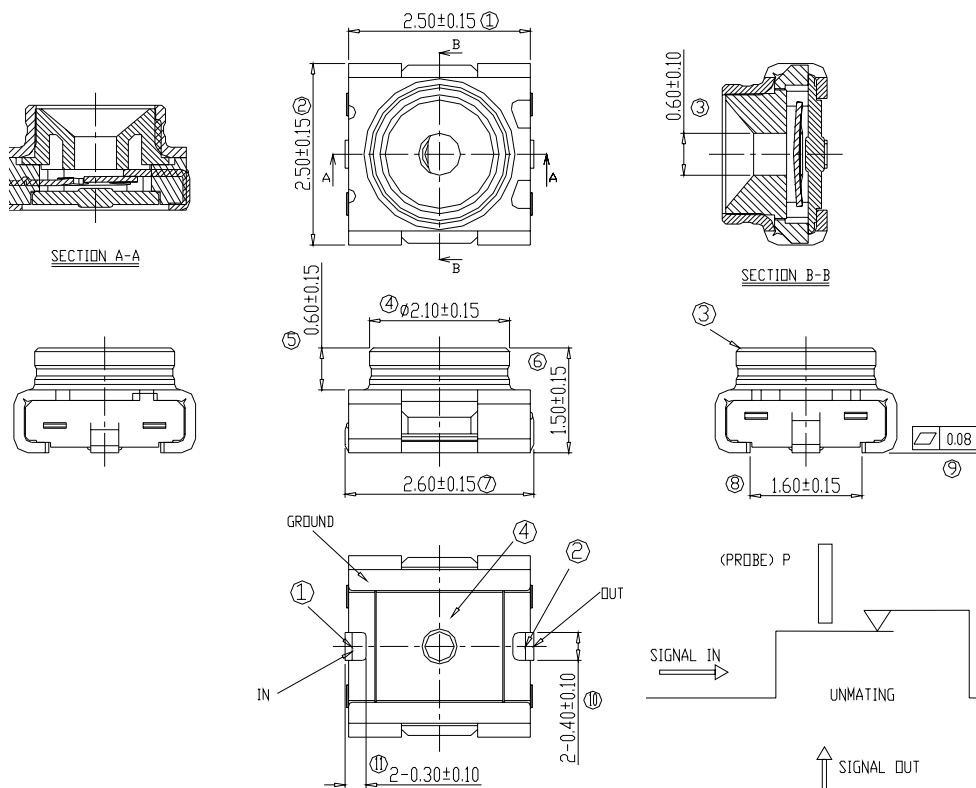

4	Case	Engineering plastic	None	1
3	Outer terminal	Copper Alloy	Ag 40u"/Ni 50u"	1
2	Output terminal(R)	Copper Alloy	Au 5u"/Ni 50u"	1
1	Input terminal(C)	Stainless Steel	Au 5u"/Ni 50u"	1
No.	Part Name	Material	Finish	Q'ty

Product specifications	DOC. No.: 651-0163-01		Rev.: C	Page: 4/6
	P/N:	Approved/Date	Approved/Date	Initiated/Date
KH-252515-G2.1		Henry 06/01/18'	Henry 06/01/18'	SAM 06/01/18'

8、Printed Circuit Board (PCB) Pad

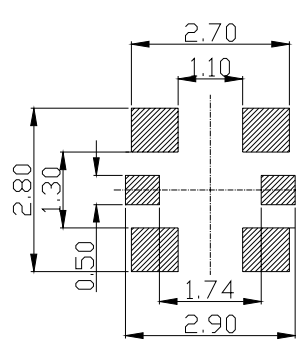

Recommend PCB Layout
General Tolerance: $\pm 0.05\text{mm}$

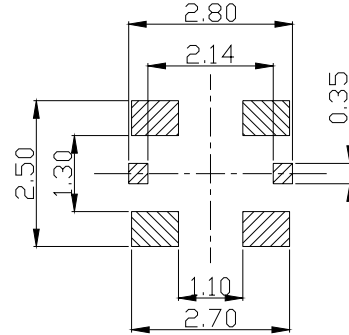

The standard solder stencil mask pattern
(Mask thickness 0.12mm)

9、Package Specifications

9.1 Peeling off Force of Cover Tape

When cover tape is peeled off as in right figure by a speed of 300mm/minute. The peeling off force should be 1.3N maximum.

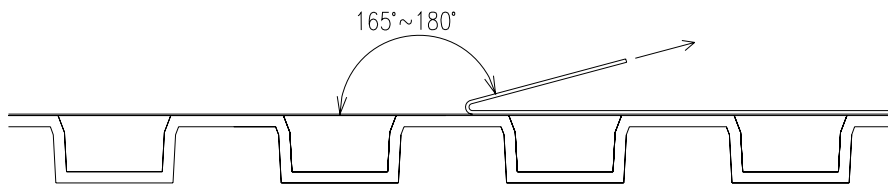

9.2 THE WAY OF PACKAGE : TAPE PACKING, 1000Pcs/REEL ($\Phi 178\text{mm}$)

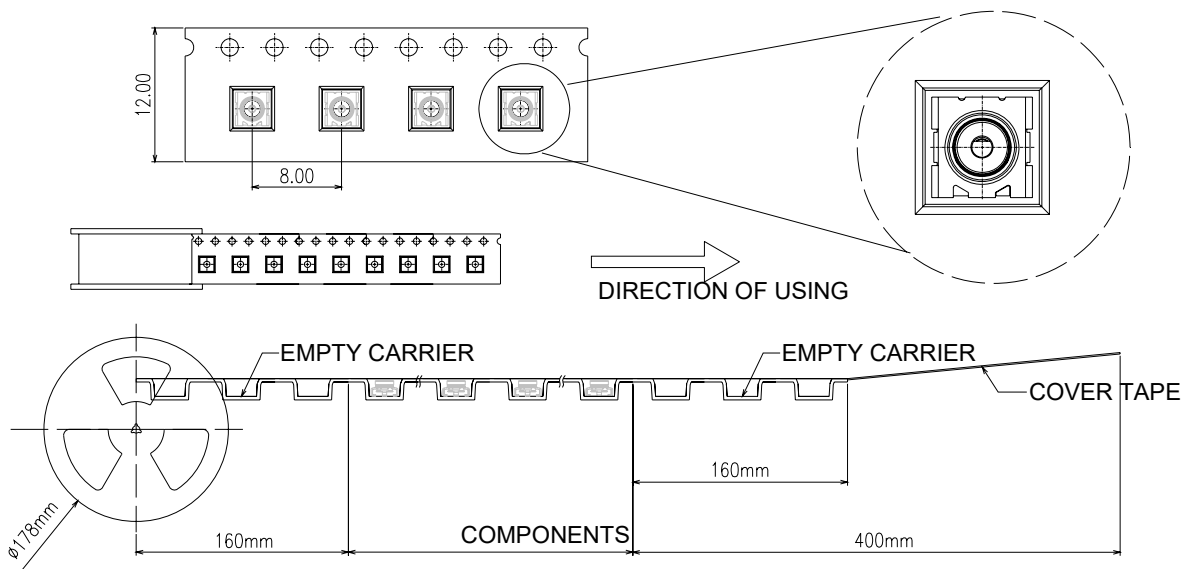

10、Storage Conditions

Temperature: $-10\sim+40\text{ }^{\circ}\text{C}$
Relative Humidity: 15~85 % RH
Life: Half year.

Product specifications	DOC. No.: 651-0163-01	Rev.: C	Page: 5/6
	P/N: KH-252515-G2.1	Approved/Date Henry 06/01/18'	Approved/Date Henry 06/01/18'

11 · Accessories for Tests

Type I :

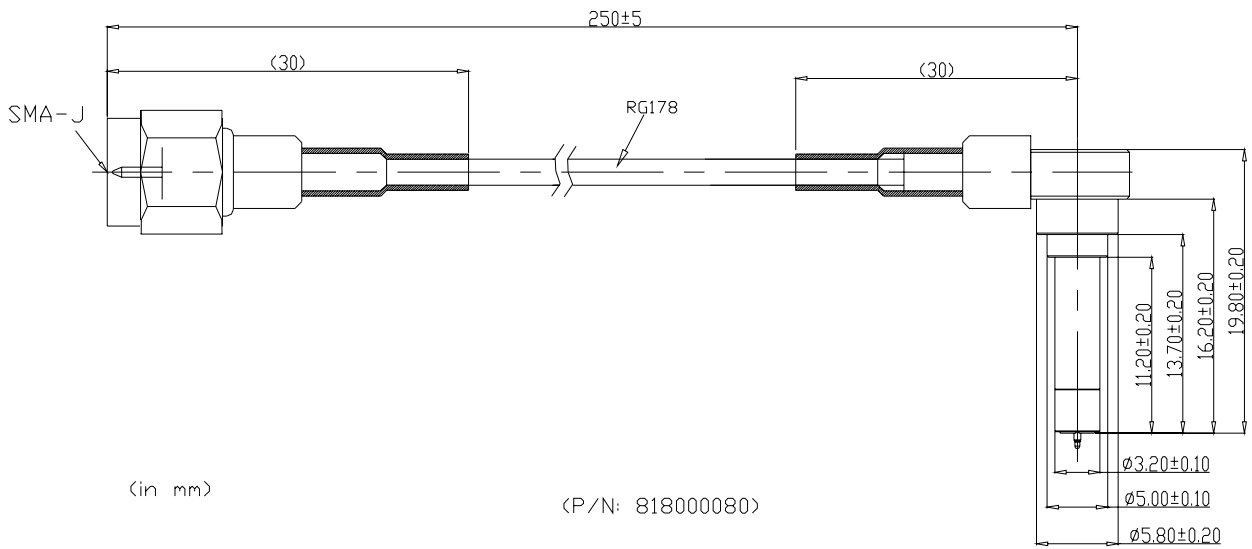

Type II :

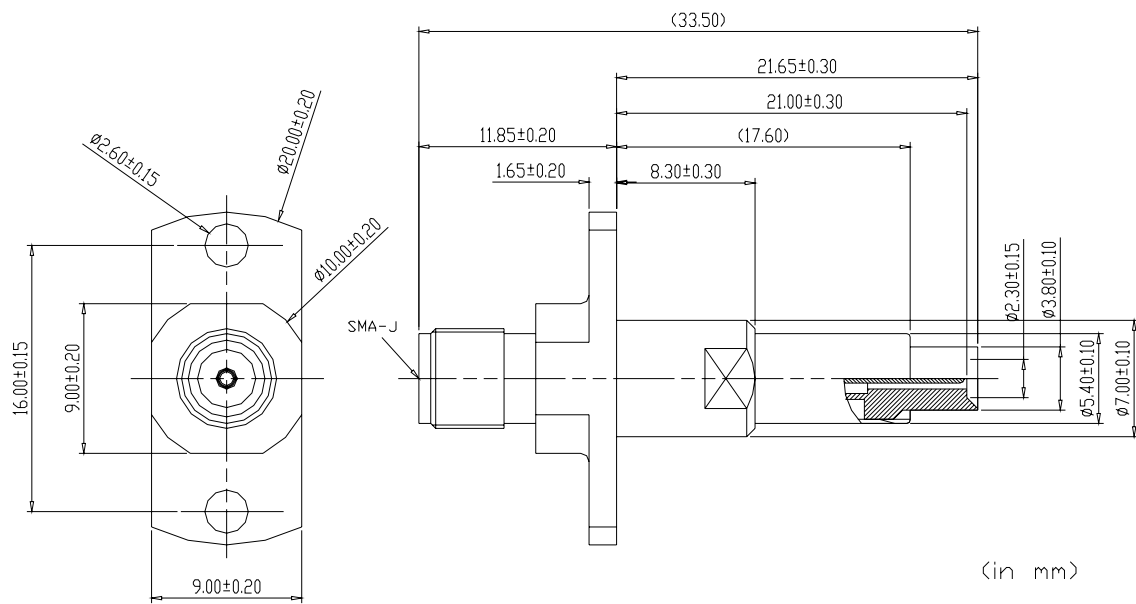

Kinghelm [®]	Product specifications		DOC. No.: 651-0163-01		Rev.: C		Page: 6/6	
	P/N:		Approved/Date		Approved/Date		Initiated/Date	
	KH-252515-G2.1		Henry 06/01/18'		Henry 06/01/18'		SAM 06/01/18'	

12、Test Plan

ITEMS		Test Group									
Test NO.	Test Items	A	B	C	D	E	F	G	H	I	J
3.1	Insulation Resistance	1		1, 5							
3.2	Withstanding Voltage	2		2, 6							
3.3	Contact Resistance	3, 12	1, 4		1, 3						
3.4	VSWR	4, 13									
3.5	Insulation	5, 14									
3.6	Insertion Loss	6, 15									
4.2	Insertion Force	7, 10									
4.3	Unmating Force	8, 11									
4.4	Mechanical Durability	9									
4.5	Adhered Force of Solder					1					
4.6	Shock		2								
4.7	Vibration		3								
5.1	High Temperature Cycling			3							
5.2	Humidity			4							
5.3	Salt Spray				2						
The least quantity of the Specimens.		5	5	5	5	5	5	5			