

Correction (Marking)	Description	Date

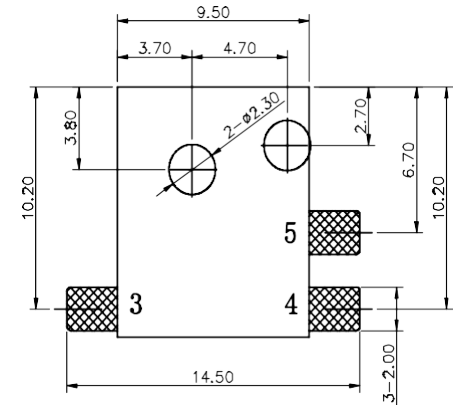

P. C. B LAYOUT TOP VIEW

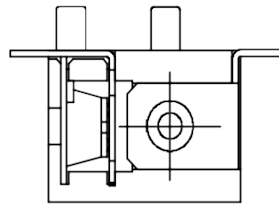
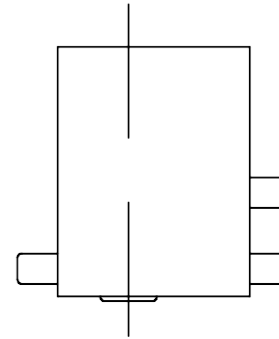
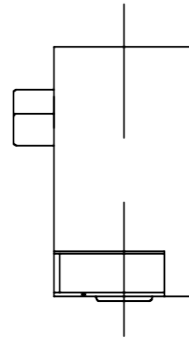
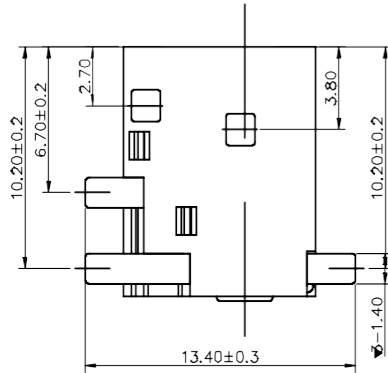
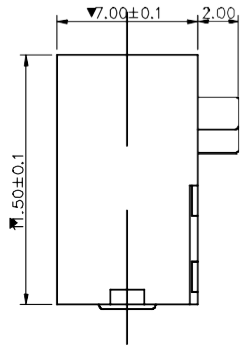
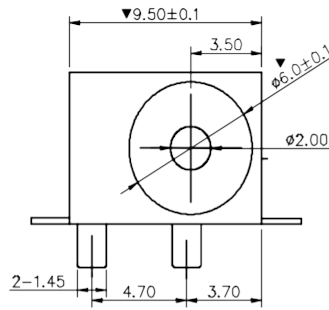
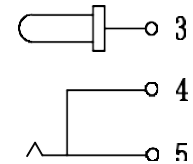

Main Technical Properties							Tolerance	Designed	Zhou Chaoai
Rated Electrical Load	DC30V0.5A			X. ±0.20	Edition	A1			
Contact Resistance	≤0.03Ω			.X ±0.10	Date	2016.05.13			
Insulation Resistance	≥100MQ			.XX ±0.05	Material				
Withstand Voltage	AC500V (50Hz) /min			.XXX ±0.02	Craft				
Insertion-withdrawal Force	3-20N			X.° ±5°	Quantity				
Range of Operating Temperature	-30-70℃			.X° ±2°	checked				
Service Life	5000times			.XX° ±1°	Approved				

No.	Item No	Product name	Quantity	Material	Specification	Finished
5	DC-044C-05	Flexible Piece Base	1	Phosphor Bronze	0.3T	Silver-plating
4	DC-044C-04	Inserting Piece Base	1	Brass	0.3T	Silver-plating
3	DC-044C-03	Flat Piece	1	Brass	0.3T	Silver-plating
2	DC-044C-02	Round Pin	1	Brass		Silver-plating
1	DC-044C-01	Base	1	PPA		Silver-plating

Department Countersignature				SHENZHEN KINGHELM ELECTRONIC CO., LTD.
Assembly Department		Marketing Department		
Injection Department		Stamping Department		
Visual Angle				WWW.BDS666.COM
Weight		scale		KH-DC-044D-2.0STM
8 sheets in total		First Sheet		0755-83044319
				DC-044D DC Electrical Socket