

CAD FILE:

**Kinghelm®**

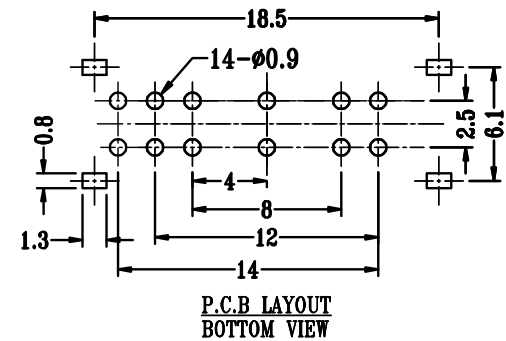
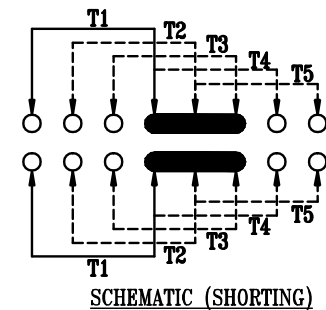
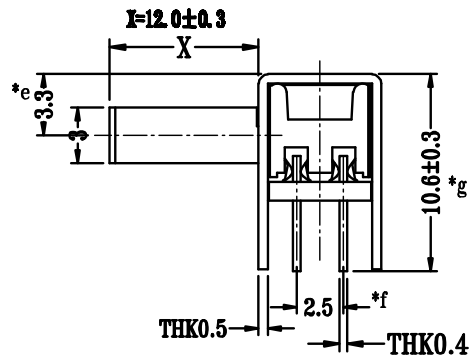
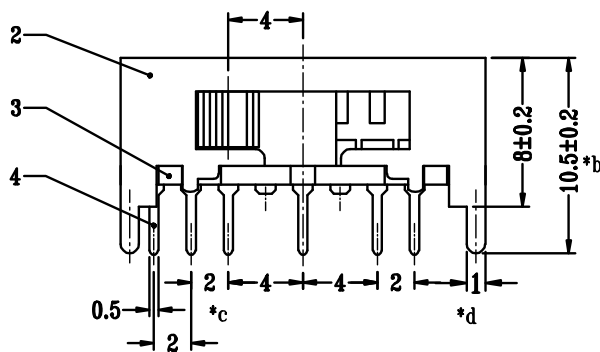
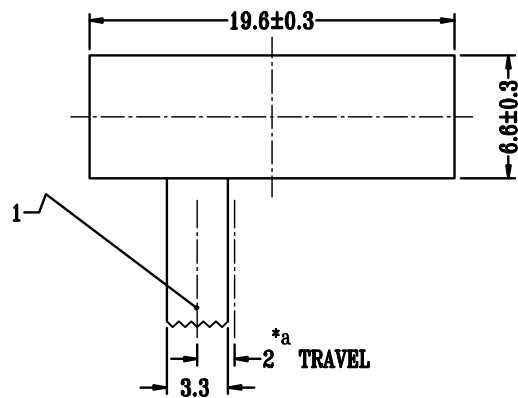

注"\*"表示关键尺寸(7个)

NO.	PARTS	MATERIALS	Q'TY	FINISH	TOLERANCE UNLESS SPECIFIED	ISSUE	DATE	DESCRIPTIONS OF REVISION	APPD.
8									
7	STEEL BALL	STEEL	2	NATURAL					
6	SPRING	STEEL WIRE	1	NATURAL	WITHIN 1.5mm : ±0.1mm	A	2020-12-29	初版	
5	CONTACT CLIP	PBS STRIP	2	Ag CLAD	OVER 1.5mm : ±0.2mm	ISSUE	DATE	DESCRIPTIONS OF REVISION	APPD.
4	TERMINAL	BRASS STRIP	12	Ag PLATED	TITLE : VERTICAL SLIDE SWITCH		UNIT : mm	DRWG NO.:	
3	BASE	PHENOLIC RESIN	1	NATURAL	MODEL: SK25D01		SCALE: 2:1	DWN.	2020-12-29
2	FRAME	STEEL STRIP	1	Ni PLATED	Shenzhen Kinghelm Electronics Co., Ltd.		www.kinghelm.net	CHK'D	2020-12-29
1	KNOB	PA66	1	BLACK	KH-SK25D01-G6			APPD.	2020-12-29